

I sent out a questionnaire to some very prominent engineers regarding the use of angle irons in Bay Area seismic retrofit work. A huge number of retrofits in the Bay Area have been and are still being retrofitted with angle irons. The purpose of this questionnaire was to evaluate their effectiveness. The letters in front of the “yes” and “no” are the initials of the engineers.

The question was as follows:

Many contractors use angle irons to bolt a house to the foundation. Use of angle irons is a local technique that is mainly found in the Bay Area. The angle iron has three holes in it; two holes attach it to the concrete and the other hole allows it to be bolted to a floor joist. My understanding is that if the distance from the top bolt in the concrete to the bolt in the joist is 12 inches, and if the distance between the two bolts in the concrete is only 6 inches, then 1000 pounds of force in the F1 direction will produce 2000 pounds of force on the lower concrete bolt and 3000 pounds of force on the upper concrete bolt and cause it to shear off. My understanding is that angle irons were looked at by the committees that wrote the three existing retrofit building codes and that they were rejected as a viable retrofit method. The answer to this question is very important since literally thousands of homes in the Bay Area have been retrofitted and are still being retrofitted in this way. Please think carefully about this as this is a method used by many contractors and engineers in the Bay Area. If you do not recommend this technique, and if most engineers participating in this survey agree with you, your answer will be immediately given to the Building Official for the city of Berkeley and other Bay Area municipalities. (Answers to the questions are marked by the first initial of the engineer’s last name”

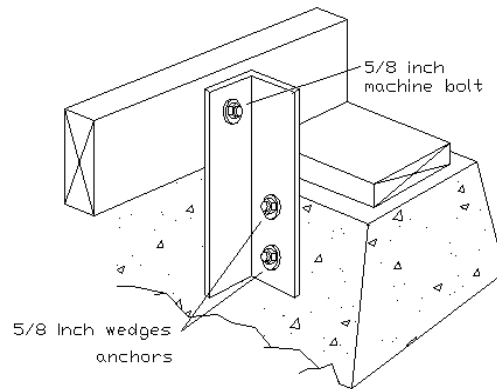

The questions are:

1) Are angle irons a viable retrofit method when trying to resist lateral loads?

Yes _____ No Ke, R, L, T, B, S, K, SH _____

2) Should angle irons be allowed in the new retrofit code?

Yes _____ No Ke, R, L, T, B, S, K, SH _____

3) If they are allowed, should there be some minimum distance ratio required for the bolts?

Ke, K, L, R, S, T, B, SH Yes _____ No _____

Comment from T - *This is a convoluted load path that will probably break down when trying to get the load into the angle iron.*

Comment from L - *This is a poor method because of torsion that will be created at the connections, no matter what the bolt spacing is.*

Comment from S - *It is too difficult to develop necessary blocking and shear clips to carry load. We looked at these as a possible mitigation measure after the Northridge earthquake and deemed them ineffective.*

Comment from R: *They will do something, but not much.*

Comment from SH with the American Wood Council. *The problem is there is no published design value for cross grain bending and angle irons will be subjected to cross grain bending. There's no way to establish a capacity.*

You are correct that every other angle bracket would work at one time using the method you described where they are installed on every other joist anyway. If the load were resisted by bearing, the wood capacity is much easier to calculate using compression perp values and the area of the angle bracket on the wood. Of course the concrete and steel capacity would need to be checked as well. Not sure what would control.

A customer asked that I retrofit his house, which had been retrofitted in this way. I wrote engineer R about it and this is what he said:

“If the question is: ‘What do I do with a house that has been retrofitted this way?’ The answer begins with figuring out how to make the installation effective. A continuous line of tightly-fitted blocking adjacent to the outstanding leg of the angle will mitigate the tendency of the joists to roll over and be a step toward effectiveness. Then, we would need to look into the connection to the joist -- is there a plate against each joist under the nut? _ If not, a Simpson BP plate should be added opposite each angle to develop the lateral load into the joists in bearing.

The strength of the angle in bending needs to be checked. To do this, you would need to know the size of the angle, and the distance from the bolt through the joist to the top bolt in the concrete at each location.

The strength of the bolts into the concrete will need to be checked. To do this you would need to know what kind of anchor bolts have been used. The approved capacity of proprietary post-installed anchors varies considerably -- some have no approved values. And, you would need to know the distance between anchors into the concrete at each installation.

Based on the above the capacity of the system could be determined. If the capacity is adequate, you need go no further. However, it is likely that you would find that the system has inadequate capacity and is not as effective as desired.

The next step would then be to decide how to supplement the system to develop the desired capacity. If it is close, adding a few more of the same angles may accomplish the needed increase in capacity. If it is way off, the supplemental system would need to be designed to best accommodate the as-found condition. The supplemental system may ignore and completely replace the angle system, or, it may be possible to develop a supplemental system that can be shown to have rigidity similar the angles so that you might be able to minimize the scope of the supplemental system. I would not try to combine the angle system with direct bolting of the mudsill to the foundation, nor with a UFP system. The rigidities of the two system differ too much, and the mudsill/UFP system would tend to resist nearly all of the load. If the bolted mudsill/UFP system had only enough strength to supplement the angles, it would probably be damaged by strong shaking before the angles would begin to function.

Additional comments from engineer R after reading engineer K's engineering analysis

I think that K's analysis is pretty good, and could be the basis for providing the customer with what he needs. The one thing that I see in K's analysis that I may do differently is the use of the strong-direction capacity for the establishing the strength -- this may not be conservative. Also, a useful analysis needs to be based on the actual condition at each anchor.

If I do an analysis, I'd like several photos of typical installations under the house, as well as conditions and the dimensions of each angle installation, and, if possible, the type and brand of the concrete anchors. Dimensions needed: size of angle, length of angle, distance from bottom of angle to each bolt and to the top of concrete, bottom of angle to bottom of floor joist, and bottom of angle to the bolt through he joist. Also: is there tightly fit blocking? Is tightly fit blocking continuous? What is the relationship of the strong direction of the installation to compass directions -- [for example, "angle is installed against the north face" or the "east face of the joist", etc.]; joist sizes and spacings. Also, what are the details of what was done at the joists-parallel-to-foundation conditions. And, are there any unusual conditions that may have unexpected impact on the effectiveness of the project -- this question is a reason that the engineer who does the analysis should be available to crawl under the house and take a personal look. A plan of the underfloor space would be a useful tool for presenting the above info.

I'm not yet proposing to do the analysis, but the above is what I think I would need to know in order to do it.

Comments from engineer K

I am attaching further calculations looking at how much earthquake load can be transferred in to the angle iron with a rim joist, and without blocking or rim joist. The numbers range between 300# and 600#, and rely more heavily on the nailing of the floor sheathing to the top of the joist when blocking is not present.

I am less concerned with the numbers and more concerned that the angle iron will create a hard spot and cause the joists to be split horizontally at mid-depth in the weak direction when the joist is pulling away from the angle. This will not likely cause collapse of anything, but could leave damage. We saw some of this type of this splitting in a diaphragm test at UC Irvine.

K

FOUNDATION ANCHOR ANCHOR W/RIM OR BLKG

WORST CASE FOR FASTENERS IS REDUND USE S.P.F NO. 5 TABLE 11N

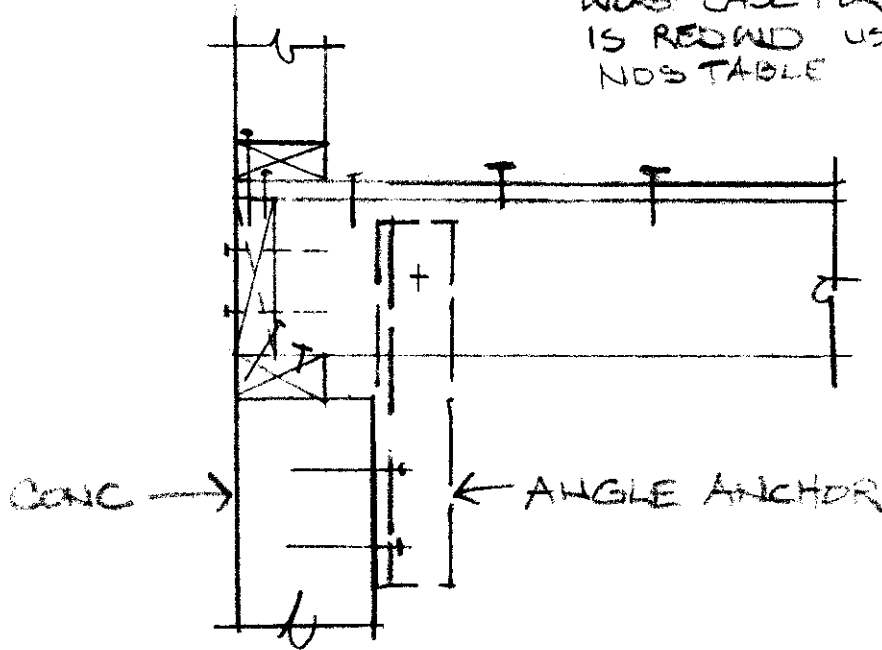

HORIZONTAL FORCE TRANSFER

ALT 1

ALT 2

2-16d #10 RIM TO JST
(END GRAIN) SINKER

4-8d TOE RIM TO JST
BOX

$Z = 100 \#$

$Z = 61 \#$

$C_{90} = 0.67$

$C_{60} = 0.83$

$C_D = 1.33$

$C_D = 1.33$

$= 2(100)(.67)(1.33) = 178 \#$

$4(61)(.83)(1.33) = 269 \#$

TOP OF JST 2-8d BOX

TOP OF JST 2-8d BOX

3/4 side

151 #

$Z = 57 \#$

$= 2(57)(1.33) = 151 \#$

BOTT OF JST 3-8db toe

BOTT OF JST

$Z = 57$

188 #

$C_{60} = 0.83$

$= 3(57)(.83)(1.33) = 188 \#$ ALT 1

ALT 2

SUM FOR RIM: $178 + 151 + 188 = 517 \#$

WEAK DIR 609

$178 + 188 = 366$

STRONG DIR 457

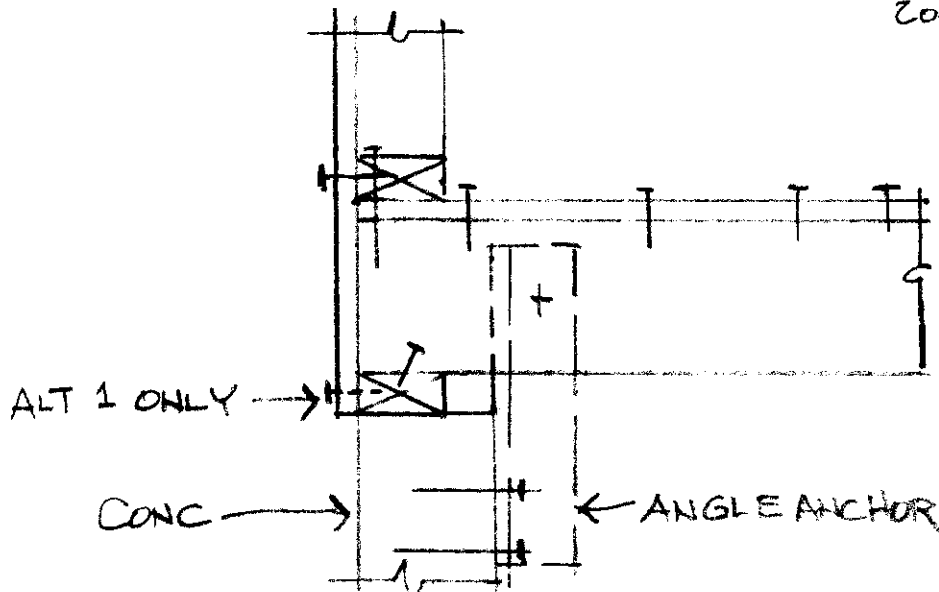
FOUNDATION ANGLE ANCHOR W/O RIM OR BLKS2001 NDS TABLE 11N
S-P-F VALUESALT 1 - EXT SHEATHING TRANSFERS
LOAD TO SILL PLATEALT 2 - EXT SHEATHING
DOES NOTTOP OF JST 5-8d box 3/4" side

$$Z = 57 \#$$

$$C_D = 1.33$$

$$= 5(57)(1.33) = 379 \#$$

TOP OF JST

$$379 \#$$

$$\text{SUM } 379 \#$$

BOTT OF JST 3-8d box toe

$$Z = 61 \#$$

$$C_{tn} = 0.83$$

$$C_D = 1.33$$

$$= 3(61)(0.83)(1.33) = 202 \#$$

$$\text{SUM } 581 \#$$

WEDGE ANCHOR CAPACITY

$$SA = 1604 \left(\frac{6}{18.75} \right) = 513 \#$$

(ECCENTRICITY INCREASED)
SEE 11-12-04 CALC

NOTE: IN WEAIR DIRECTION, CROSS-GRAIN TENSION FAILURE OF JST IS LIKELY - TOP OF JST NAILS WILL PULL JST TOP. ECCENTRICITY WILL BE TO BOLT AT MID-HT SAW JST FAILURE IN ACCIDENT TESTS.